



# **Intel Digital Random Number Generator SP800-90B Non- Proprietary Public Use Document**

**Intel Entropy Source**

---

***May 2023***

**Revision 0.3.4**

**Intel Confidential**



**Notice: This document contains information on products in the design phase of development. The information here is subject to change without notice. Do not finalize a design with this information.**

Intel technologies' features and benefits depend on system configuration and may require enabled hardware, software, or service activation. Learn more at [intel.com](http://intel.com), or from the OEM or retailer.

No computer system can be absolutely secure. Intel does not assume any liability for lost or stolen data or systems or any damages resulting from such losses.

You may not use or facilitate the use of this document in connection with any infringement or other legal analysis concerning Intel products described herein. You agree to grant Intel a non-exclusive, royalty-free license to any patent claim thereafter drafted which includes subject matter disclosed herein.

No license (express or implied, by estoppel or otherwise) to any intellectual property rights is granted by this document. The products described may contain design defects or errors known as errata which may cause the product to deviate from published specifications. Current characterized errata are available on request.

This document contains information on products, services and/or processes in development. All information provided here is subject to change without notice. Contact your Intel representative to obtain the latest Intel product specifications and roadmaps.

Intel disclaims all express and implied warranties, including without limitation, the implied warranties of merchantability, fitness for a particular purpose, and non-infringement, as well as any warranty arising from course of performance, course of dealing, or usage in trade.

Tests document performance of components on a particular test, in specific systems. Differences in hardware, software, or configuration will affect actual performance. Consult other sources of information to evaluate performance as you consider your purchase. For more complete information about performance and benchmark results, visit <http://www.intel.com/performance>.

Cost reduction scenarios described are intended as examples of how a given Intel-based product, in the specified circumstances and configurations, may affect future costs and provide cost savings. Circumstances will vary. Intel does not guarantee any costs or cost reduction.

Results have been estimated or simulated using internal Intel analysis or architecture simulation or modeling and provided to you for informational purposes. Any differences in your system hardware, software or configuration may affect your actual performance.

Intel does not control or audit third-party benchmark data or the web sites referenced in this document. You should visit the referenced web site and confirm whether referenced data are accurate.

Intel is a sponsor and member of the Benchmark XPRT Development Community and was the major developer of the XPRT family of benchmarks. Principled Technologies is the publisher of the XPRT family of benchmarks. You should consult other information and performance tests to assist you in fully evaluating your contemplated purchases.

Copies of documents which have an order number and are referenced in this document may be obtained by calling 1-800-548-4725 or by visiting [www.intel.com/design/literature.htm](http://www.intel.com/design/literature.htm).

Intel, the Intel logo, Intel Atom and Xeon are trademarks of Intel Corporation in the U.S. and/or other countries.

\*Other names and brands may be claimed as the property of others

Copyright © 2023, Intel Corporation. All Rights Reserved.

# Contents

---

<b>1</b>	<b>Description.....</b>	<b>5</b>
<b>2</b>	<b>Security Boundary.....</b>	<b>6</b>
<b>3</b>	<b>Operating Conditions.....</b>	<b>8</b>
<b>4</b>	<b>Configuration Settings .....</b>	<b>9</b>
<b>5</b>	<b>Physical Security Mechanisms.....</b>	<b>10</b>
<b>6</b>	<b>Conceptual Interfaces .....</b>	<b>11</b>
<b>7</b>	<b>Min Entropy Rate.....</b>	<b>12</b>
<b>8</b>	<b>Health Tests .....</b>	<b>14</b>
<b>9</b>	<b>Maintenance.....</b>	<b>15</b>
<b>10</b>	<b>Required Testing .....</b>	<b>16</b>

## Figures

Figure 2-1. DRBG Security Boundary.....	7
---	---

## Tables

Table 1-1. List of Applicable Devices .....	5
Table 3-1. Operating Conditions .....	8



## Revision History

---

Revision Number	Description	Date
0.3.4	<ul style="list-style-type: none"><li>Updates related to Federal Information Processing Standard (FIPS) 140-3 IG</li></ul>	May 2023
0.3.3	<ul style="list-style-type: none"><li>Title update, CHIP name update.</li></ul>	April 2023
0.3.2	<ul style="list-style-type: none"><li>Initial release of the document.</li></ul>	March 2023

# 1 Description

---

The Intel Entropy Source is a physical (P) entropy source.

The circuit component is RNG\_ES\_DNV\_1.0

The synthesizable RTL component is DNV-COOP-RTL1.0

All components of the entropy source are hardware, consisting of logical and electronic components bounded in a rectangle of silicon. There is no firmware or software within the entropy source.

The entropic data from the entropy source is Non-Independent and Identically Distributed (IID).

This PUD is applicable to the following products:

**Table 1-1. List of Applicable Devices**

Processor Name	Processor Name
Intel Atom® Processor C3308	Intel Atom® Processor C3558RC
Intel Atom® Processor C3314	Intel Atom® Processor C3708
Intel Atom® Processor C3324	Intel Atom® Processor C3734
Intel Atom® Processor C3336	Intel Atom® Processor C3750
Intel Atom® Processor C3338	Intel Atom® Processor C3754
Intel Atom® Processor C3338R	Intel Atom® Processor C3758
Intel Atom® Processor C3364	Intel Atom® Processor C3758R
Intel Atom® Processor C3436L	Intel Atom® Processor C3808
Intel Atom® Processor C3508	Intel Atom® Processor C3830
Intel Atom® Processor C3509	Intel Atom® Processor C3850
Intel Atom® Processor C3518	Intel Atom® Processor C3858
Intel Atom® Processor C3534	Intel Atom® Processor C3908
Intel Atom® Processor C3538	Intel Atom® Processor C3934
Intel Atom® Processor C3544	Intel Atom® Processor C3950
Intel Atom® Processor C3558	Intel Atom® Processor C3955
Intel Atom® Processor C3558R	Intel Atom® Processor C3958

## 2 *Security Boundary*

---

The entropy source security boundary surrounds the set of components referred to as the Digital Random Number Generator (DRNG) core that include the noise source digitizer, Continuous Health Tests (CHT), Advanced Encryption Standard (AES)- Cipher Block Chaining - Message Authentication Code (CBC-MAC) Vetted Conditioning Component, Deterministic Random Bit Generator (DRBG), Non-deterministic Random Bit Generator (NRBG), and register interface.

For use as a full entropy source, the NRBG output of the DRNG is the necessary output. This is accessed through the Intel CPU instruction "RdSeed".

The security boundary is a sub boundary within the DRNG. Components outside the security boundary but within the DRNG are to attach to the local bus, clock, and power systems on the chip.

The DRNG security boundary is not a Federal Information Processing Standard (FIPS) 140 security boundary. It is designed to be usable within a larger FIPS 140 security boundary through compliance with SP800-90A, B, and draft C along with relevant requirements in ISO/IEC 19790-2012 and FIPS 140-3.

The bold outline in [Figure 2-1](#) shows the security boundary of the entropy source and other RNG components.

The NRBG output path to the region block is the output of the full entropy source, as an RBG3 construction.

The DRBG output path to the region block is the output of the DRBG, as an RBG2 construction.

The NRBG construction is the XOR (RBG3) construction NRBG from Draft SP800-90C. This XORs the output of the conditioner with an output from the DRBG to form the NRBG output. The strength of the XOR is entirely dependent on the full entropy of the conditioner output. The DRBG's input into the XOR, as well as the XOR operation itself are not considered part of the conditioning chain.

The width of these operations is 128 bits, driven by the output size of AES. The registers sizes are 64 bits and in the logic, this width transforming is performed using a First In, First Out (FIFO) that is 64 bits wide and takes in 128 bits as two 64-bit entries and outputs 64 bits to match the register width.

**Figure 2-1. DRBG Security Boundary**

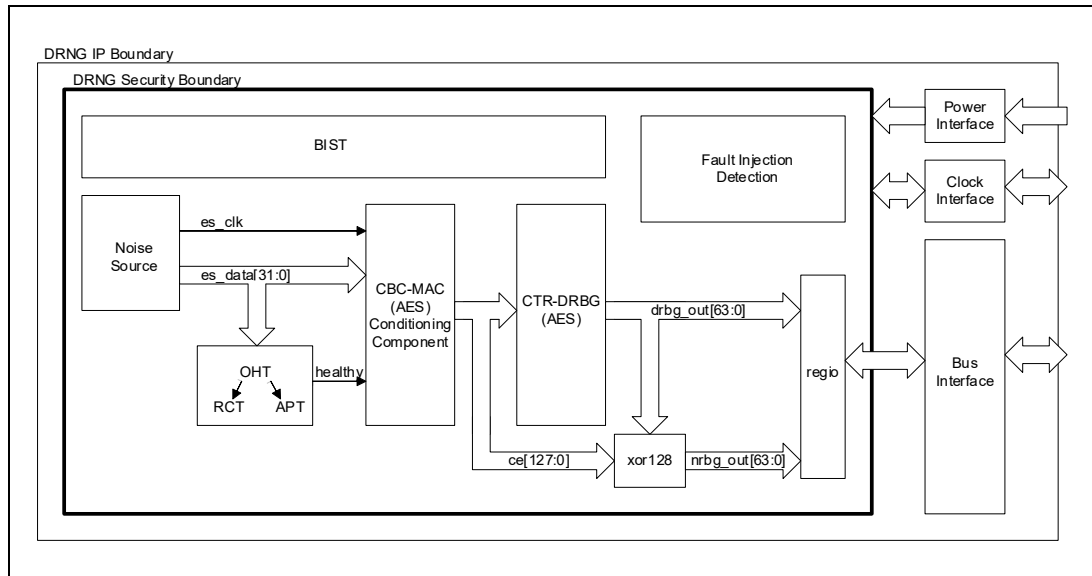

In the context of an Intel CPU, the DRNG register that presents the NRBG output to the local bus is called `agetdata`. This register is read by the CPU whenever the `RdSeed` instruction is executed. The result is passed to the target register of the instruction and the success or failure signaled in the carry flag.

This report is applicable to the devices in [Table 1-1](#). The silicon manufacturing process, Integrated Circuit (IC) design and DRNG design are identical for each of these devices. Differences between these devices are the set of enabled features, which has no influence on the RNG behavior.



## 3 *Operating Conditions*

---

The entropy source is guaranteed to operate within the designated operating envelope in the datasheet of the chip. In **Intel Atom® Processor C3958** the operating envelope is as follows:

**Table 3-1. Operating Conditions**

Parameter	Minimum	Maximum
Temperature	0 °C	83 °C

These conditions are taken from the Intel Automated Relational Knowledge-Base (ARK) specifications:

<https://www.intel.com/content/www/us/en/products/sku/97927/intel-atom-processor-c3958-16m-cache-up-to-2-0-ghz/specifications.html>



## 4 *Configuration Settings*

---

There are no configuration settings accessible at any privilege level to software running in the CPU.

## 5 *Physical Security Mechanisms*

---

The RNG contains a security boundary described in [Section 2](#). In the operating mode of the RNG, there is hardware enforcement of the security of the boundary.

Specifically:

- Diagnostic output of raw data from the boundary is disabled.
- Debugging port access to internal state of the RNG is disabled at the boundary.
- Configuration input written to registers is ignored and the default configuration is enforced.
- Algorithms are implemented to detect stuck output failures.
- Register write privileges are enforced in hardware.

When an alarm is triggered, the RNG resets itself and re-runs Built-In Self-Test (BIST). It is not possible to distinguish between a failure due to attack or environmental bounds violation or a rare false positive error. The re-running of BIST will lead to the RNG failing if the BIST fails. In the case of a transitory error, the RNG will recover when BIST is re-run.

The packaging of the chip is a tamper evident enclosure.

## 6 *Conceptual Interfaces*

---

For consuming applications running in software on the CPU, `GetEntropy(n)` is implemented by the `RdSeed` instruction, where  $n$  can be one of 16, 32 or 64, depending on the size of the target register.

Internally to the security boundary, for feeding conditioner output data to the DRBG, `Get_entropy()` is implemented in digital logic between the conditioner and DRBG in the form of a 128-bit wide FIFO.

## 7 Min Entropy Rate

---

The assessed entropy from the noise source, as per Section 3.1.4.2 of the SP800-90B, is  $\min(H_r, H_c, H_I) = 0.6$  bits of entropy per bit of data.

$H_{out}$  from the CBC-MAC conditioning component, assessed according to Section 3.1.5 of the SP800-90B, is  $1-\varepsilon$  where  $\varepsilon \ll 2^{-32}$ , meeting the draft requirement for full entropy in draft SP800-90C.

The assessment of the conditioner output entropy is computed with the lower bound of the conditioner input data set above the CHT pass threshold of 0.6, the conditioner entropy output assessed using the equations in SP800-90B, Section 3.1.5.1.2, are:

```
H_out = Output_Entropy(n_in, n_out, nw, h_in) where
n_in   = 512
n_out  = 128
nw     = 128
h_in   = 0.6 * 512 = 307.2
```

When using a conditioning component listed in Section 3.1.5.1.1 (given the assurance of correct implementation by Cryptographic Algorithm Validation Program [CAVP] testing), the entropy of the output is estimated as:

$$h_{out} = Output\_Entropy(n_{in}, n_{out}, nw, h_{in})$$

Where  $Output\_Entropy(n_{in}, n_{out}, nw, h_{in})$  is described as follows:

1. Let  $P_{high} = 2^{-h_{in}}$  and  $P_{low} = \frac{(1-P_{high})}{2^{n_{in}-1}}$ .
2.  $N = \min(n_{out}, nw)$ .
3.  $\Psi = 2^{n_{in}-n} P_{low} + P_{high}$
4.  $U = 2^{n_{in}-n} + \sqrt{2n(2^{n_{in}-n})\ln(2)}$
5.  $\Omega = U \times P_{low}$
6. Return  $-\log_2(\max(\Psi, \Omega))$

This was evaluated using 1,000 binary digit floating point arithmetic.

```
#!/usr/bin/env python3

from __future__ import print_function

import UsrIntel.R1 # Intel specific import to get the standard libraries
import math
from mpmath import *

PRECISION = 1000 # 1,000 of precision.
```

```

def output_entropy(n_in,n_out,nw, h_in):
    n = min(n_out,nw)
    ttninmn = mpf(2.0)**(n_in-n)
    p_high = mpf(2.0)**(-h_in)
    p_low = (mpf(1.0)-p_high)/((mpf(2.0)**n_in)-mpf(1.0))
    phi = ttninmn*p_low + p_high
    U = ttninmn + sqrt(mpf(2.0) * n * ttninmn * log(mpf(2.0)))
    w = U * p_low
    return -log(max(phi,w),2)

if __name__=="__main__":
    mp.prec = PRECISION
    entropy_rate = 0.6
    n_in = 512
    h_in = n_in*entropy_rate

    entropy = output_entropy(mpf(n_in), mpf(128.0), mpf(128.0), mpf(h_in))
    epsilon = mpf(128.0)-entropy

    # compute human readable epsilon
    for i in range(1,1024):
        power = mpf(i)
        ne = epsilon*(2**power)
        if ne > 1:
            print("epsilon = %s*2^-%d" % (nstr(ne,8),i))
            break

> ./pud_entropy.py
epsilon = 1.255939*2^-179

```

The result shows the lower bound of epsilon for entropy rates above the pass threshold of the CHT is, to four digits of precision  $1.255 \cdot 2^{-179}$ , which meets the requirement for epsilon to be less than  $2^{-32}$ .

## 8 Health Tests

---

The DRNG includes:

- Continuous Health Tests (CHT).
- Startup Noise Source Health Tests.
- Startup Logic Integrity BIST.

The CHT is composed of a short-term test yielding a pass/fail over individual 256-bit blocks of noise source data, and a long-term evaluation of the pass/fail history of the past 256 blocks (totaling 65536 bits) to infer an entropy source failure. The failure condition is invoked when the pass/fail rate drops below 50%.

The logic integrity test is one of the startup tests. This performs a test of the digital logic by running deterministic random sequences through all the logic and testing the resulting output against the expected result.

The Startup Noise Source Health Test involves running the CHT for a probationary period of 65536 bits from the noise source. When the test is complete, assuming the test passes, the RNG enters the operational state. This happens during CPU startup and completes before the first CPU instructions can execute. Thus, `RdSeed` is available from initial instruction execution time.

The startup test is invoked at power-on or exiting the reset state. Thus, the startup tests can be invoked by power cycling the CPU or resetting the CPU.

A failure any of the startup tests (logic integrity or noise source health test) will be reflected as a BIST failure in the internal status register, which leads to an MCHECK failure of the CPU.

Following the startup tests, the CHT continues to run. Should failure condition of the CHT test be encountered after the startup tests have completed, this may be either the result of a soft error or a hard error. The test will continue to run and should the entropy quality return, it will exit the failure state. In the failure state, no more random numbers are issued, and the failure state is reflected in the internal state registers, which is visible at the instruction interface by the repeated failure to deliver random numbers, through the returned carry flag of the `RdRand` and `RdSeed` instructions being 0.

A sequence of 1000 back-to-back 0 carry flags on `RdSeed` can be inferred to be an error. Should some condition exist (for example, out of specification operating condition), cessation of that condition will lead to resumption of the supply of random numbers.

A less computationally expensive test of failure is the response from the `RdRand` instruction (not a noise source output, but an RBG2 output), which due to its higher output rate has a 0% chance of underflows arising from high consumption demand by other threads, and so 10 back-to-back failures are specified as a runtime error.

## 9 *Maintenance*

---

There are no maintenance action requirements.

## ***10 Required Testing***

---

We performed raw noise testing using the non-IID lower bound entropy tests of the SP800-90B Entropy Assessment software tool, showing the entropy from the noise source to exceed the minimum input threshold of 0.299 of the vetted conditioning components.

We performed restart testing using the SP800-90B Entropy Assessment software tool, showing the startup min entropy of  $H_r$  and  $H_c$  to be greater than 50% of  $H_I$ .